



### Standard Features

- Spare Tire Included
- Slide in Ramps
- Stake Pockets
- Scissor hoist – Power Up / Power Down
- Adjustable Coupler
- Roll Up Tarp
- Rear Drop Down Stabilizer Jacks
- Aluminum Pump Box
- 110V Battery Charger
- PPG DTM 2 Part Epoxy Paint

### Specifications

<b>Axle:</b>	(2) 7,000 lb Lippert Spring	<b>Floor &amp; Wall</b>	10ga Floor / 12ga Wall
<b>Hoist:</b>	Champion CS515T 7 Ton	<b>Frame:</b>	6 X 2 X 0.148 HSS
<b>Jack:</b>	7,000 lb Top Wind Bolted	<b>Lights:</b>	LED
<b>Ramp:</b>	4,000 lb Mid Span	<b>Electric Plug:</b>	7 Wire RV
<b>Wheels:</b>	235/80R16 E Steel	<b>Safety Chains:</b>	16,200 lb
<b>Tailgate:</b>	Steel Barn Door	<b>Paint Specs</b>	PPG 2-Part Epoxy DTM
<b>Coupler:</b>	21,000 lb Demco Adjustable		

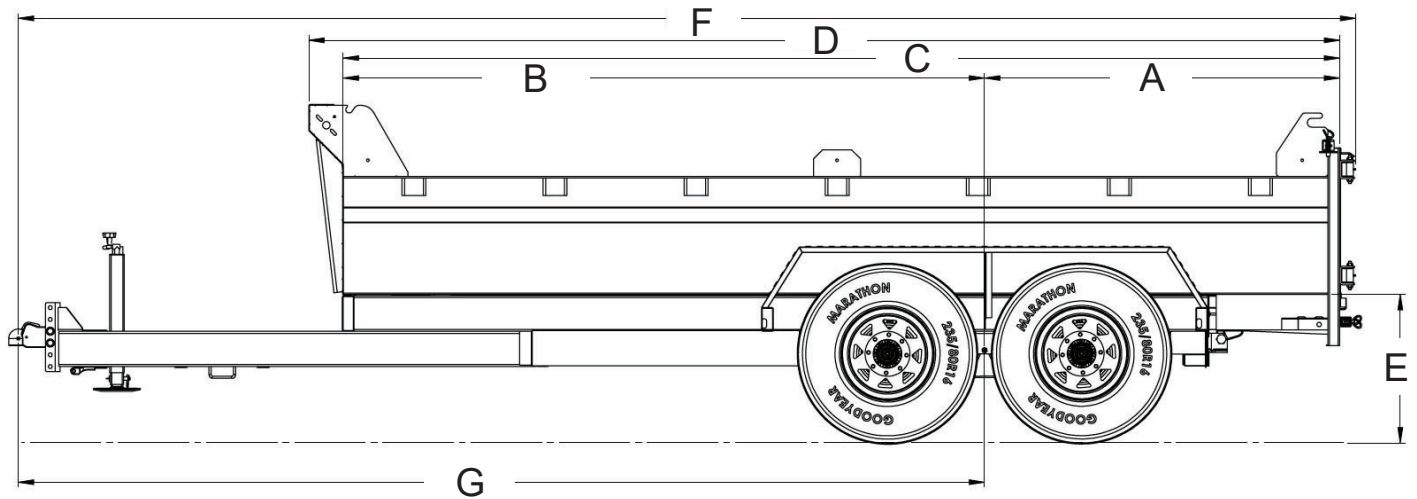

## Dimensions

Model	A	B	C	D	E	F	G
SL714-14K	60 1/2"	109"	169 1/2"	175 1/2"	25 1/4"	227 1/2"	164 3/8"

Model	Description	Net Weight	GVWR	Payload Cap.
SL714-14K	7' x 14' 14,000 lb. Tandem Axle Black/Charcoal	3,120 lb	15,400 lb	12,280 lb



Specs are subject to change without notice. Please contact Southland Trailer Corp Product Specialist for price confirmation on all Products. - Revised January 2024



### Standard Features

- Spare Tire Included
- Slide in Ramps
- Stake Pockets
- Scissor hoist – Power Up / Power Down
- Adjustable Coupler
- Roll Up Tarp
- Rear Drop Down Stabilizer Jacks
- Aluminum Pump Box
- 110V Battery Charger
- PPG DTM 2 Part Epoxy Paint

### Specifications

<b>Axle:</b>	(2) 8,000 lb Lippert Spring	<b>Floor &amp; Wall</b>	10ga Floor / 10ga Wall
<b>Hoist:</b>	Champion CS615T 9 Ton	<b>Frame:</b>	6 X 2 X 0.188 HSS
<b>Jack:</b>	12,000 lb Side Wind Jack Bolted	<b>Lights:</b>	LED
<b>Ramp:</b>	4,500 lb Mid Span	<b>Electric Plug:</b>	7 Wire RV
<b>Wheels:</b>	235/85R16 F Steel	<b>Safety Chains:</b>	16,200 lb
<b>Tailgate:</b>	Steel Three Way Barn/Spreader	<b>Paint Specs</b>	PPG 2-Part Epoxy DTM
<b>Coupler:</b>	21,000 lb Demco Adjustable		

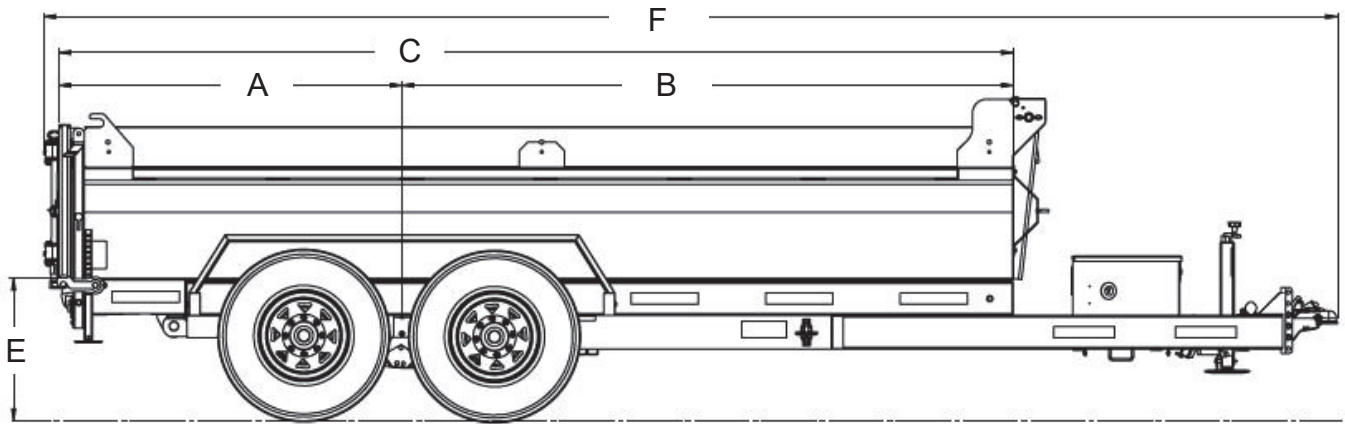

## Dimensions

Model	A	B	C	D	E	F
SL714-16K	60 3/4"	109 1/4"	170"	176"	25 1/4"	228"

Model	Description	Net Weight	GVWR	Payload Cap.
SL714-16K	7' x 14' 16,000 lb. Tandem Axle Black/Charcoal	3,695 lb	17,385 lb	13,690 lb



Specs are subject to change without notice. Please contact Southland Trailer Corp Product Specialist for price confirmation on all Products. - Revised January 2024

## SL714-16KHD 7' x 14', 16,000 lb. Heavy Duty Tandem Axle Dump Trailer



### Standard Features

- Spare Tire Included
- Slide in Ramps
- Stake Pockets
- Scissor hoist – Power Up / Power Down
- Adjustable Coupler
- Roll Up Tarp
- Rear Drop Down Stabilizer Jacks
- Aluminum Pump Box
- 110V Battery Charger
- PPG DTM 2 Part Epoxy Paint

### Specifications

<b>Axle:</b>	(2) 8,000 lb Lippert Spring	<b>Floor &amp; Wall</b>	3/16 Floor / 10ga Wall
<b>Hoist:</b>	Champion CS615T 9 Ton	<b>Frame:</b>	6 X 2 X 0.188 HSS
<b>Jack:</b>	8,000 lb Hydraulic Bolted	<b>Lights:</b>	LED
<b>Ramp:</b>	4,500 lb Mid Span	<b>Electric Plug:</b>	7 Wire RV
<b>Wheels:</b>	235/85R16 G Steel	<b>Safety Chains:</b>	16,200 lb
<b>Tailgate:</b>	Steel Three Way Barn/Spreader	<b>Paint Specs</b>	PPG 2-Part Epoxy DTM
<b>Coupler:</b>	21,000 lb Demco Adjustable		

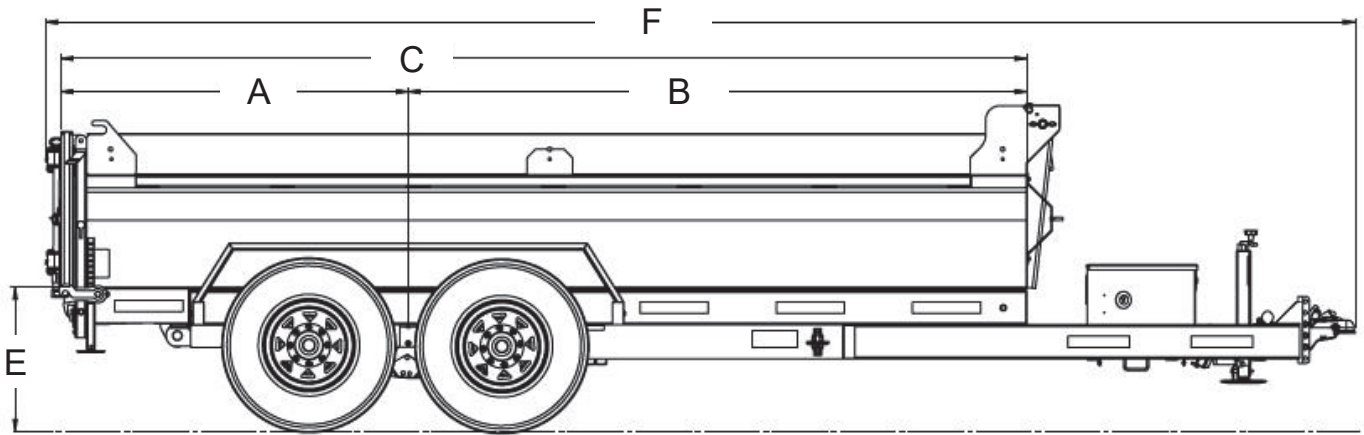

## Dimensions

Model	A	B	C	D	E	F
SL714-16KHD	60 3/4"	109 1/4"	170"	176"	25 1/2"	228"

Model	Description	Net Weight	GVWR	Payload Cap.
SL714-16KHD	7' x 14' 16,000 lb. Tandem Axle Black/Charcoal	3,785 lb	17,560 lb	13,775 lb



Specs are subject to change without notice. Please contact Southland Trailer Corp Product Specialist for price confirmation on all Products. - Revised January 2024

## SL714-16KHS 7' x 14', 16,000 lb. High Side Tandem Axle Dump Trailer with 2-Way Tailgate



### Standard Features

- Spare Tire Included
- Slide in Ramps
- Stake Pockets
- Scissor hoist – Power Up / Power Down
- Adjustable Coupler
- Roll Up Tarp
- Rear Drop Down Stabilizer Jacks
- Aluminum Pump Box
- 110V Battery Charger
- PPG DTM 2 Part Epoxy Paint

### Specifications

<b>Axle:</b>	(2) 8,000 lb Lippert Spring	<b>Floor &amp; Wall</b>	3/16 Floor / 10ga Wall
<b>Hoist:</b>	Champion CS615T 9 Ton	<b>Frame:</b>	6 X 2 X 0.188 HSS
<b>Jack:</b>	12,000 lb Side Wind Bolted	<b>Lights:</b>	LED
<b>Ramp:</b>	4,500 lb Mid Span	<b>Electric Plug:</b>	7 Wire RV
<b>Wheels:</b>	235/85R16 G Steel	<b>Safety Chains:</b>	16,200 lb
<b>Tailgate:</b>	Steel Two Way Barn/Spreader	<b>Paint Specs</b>	PPG 2-Part Epoxy DTM
<b>Coupler:</b>	21,000 lb Demco Adjustable		



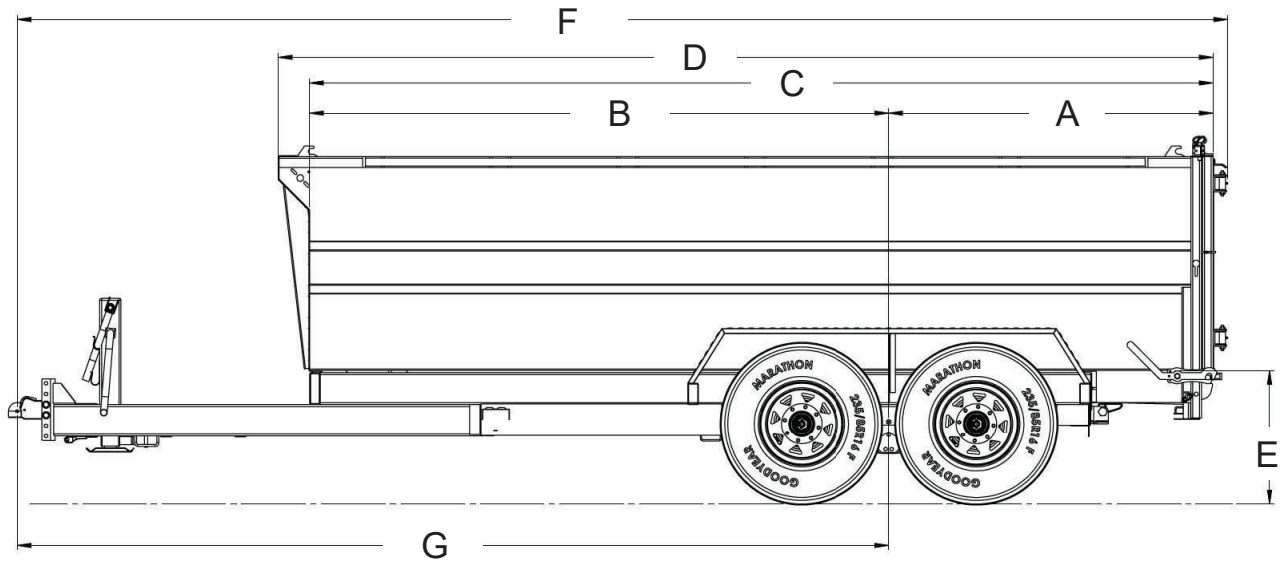

## Dimensions

Model	A	B	C	D	E	F	G
SL610-16KHS	60 3/4"	109 1/4"	170"	174"	25 1/2"	228"	164 7/16"

Model	Description	Net Weight	GVWR	Payload Cap.
SL714-16KHS	7' x 14' 16,000 lb. Tandem Axle Black/Charcoal	4,175 lb	17,560 lb	13,385 lb



Specs are subject to change without notice. Please contact Southland Trailer Corp Product Specialist for price confirmation on all Products. - Revised January 2024



## SL716-20KHD 7' x 16', 20,000 lb. Tandem Axle Dump Trailer with 3-Way Tailgate



### Standard Features

- Spare Tire Included
- Slide in Ramps
- Stake Pockets
- Scissor hoist – Power Up / Power Down
- Adjustable Coupler
- Roll Up Tarp
- Rear Drop Down Stabilizer Jacks
- Aluminum Pump Box
- 110V Battery Charger
- PPG DTM 2 Part Epoxy Paint

### Specifications

<b>Axle:</b>	(2) 10,000 Lippert Torsion	<b>Floor &amp; Wall:</b>	3/16 Floor / 10ga Wall
<b>Hoist:</b>	Champion CS6-20T 13 Ton	<b>Frame:</b>	Engineered Beam 90 KSI Steel
<b>Jack:</b>	14,000 lb Hydraulic Bolted	<b>Lights:</b>	LED
<b>Ramp:</b>	4,500 lb Mid Span	<b>Electric Plug:</b>	7 Wire RV
<b>Wheels:</b>	235/75R17.5 H Steel	<b>Safety Chains:</b>	26,400 lb
<b>Tailgate:</b>	Steel Three Way Barn/Spreader	<b>Paint Specs:</b>	PPG 2-Part Epoxy DTM
<b>Coupler:</b>	21,000 lb Demco Adjustable		

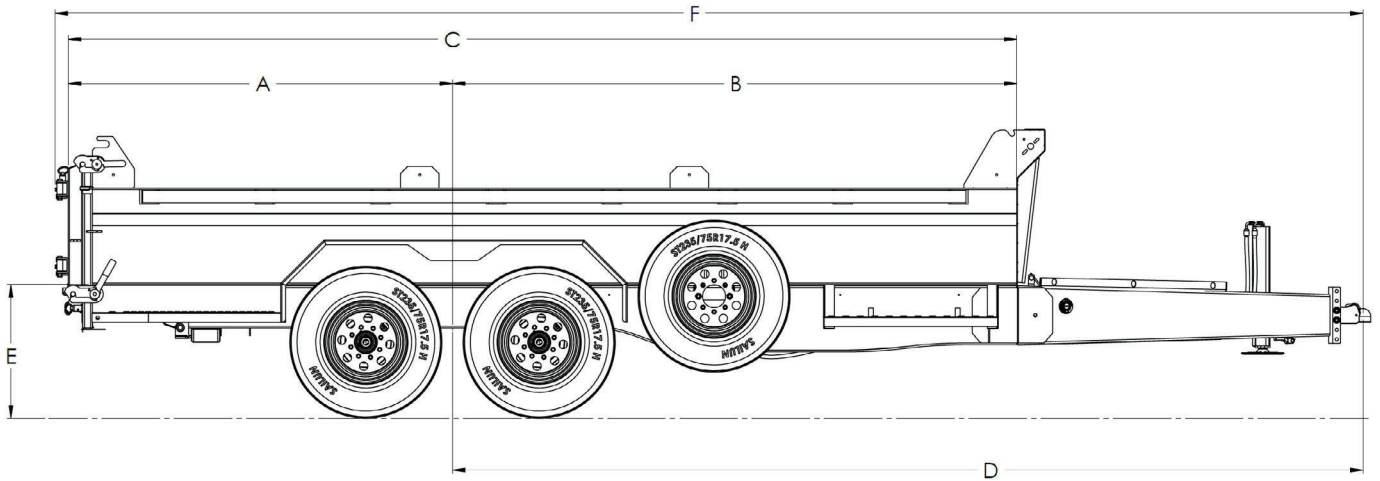

## Dimensions

Model	A	B	C	D	E	F
SL716-20KHD	80"	117"	197"	189"	27 3/4"	272"

Model	Description	Net Weight	GVWR	Payload Cap.
SL716-20KHD	7' x 14' 16,000 lb. Tandem Axle Black/Charcoal	5,700 lb	21,000 lb	15,300 lb



Specs are subject to change without notice. Please contact Southland Trailer Corp Product Specialist for price confirmation on all Products. - Revised January 2024

## SL716G-24K - 7' x 16', 24,000 lb. Tandem Axle Gooseneck Dump Trailer with 2-Way Tailgate



### Standard Features

- Spare Tire Included
- Slide in Ramps
- Stake Pockets
- Scissor hoist – Power Up / Power Down
- Adjustable Coupler
- Roll Up Tarp
- Rear Drop Down Stabilizer Jacks
- Aluminum Pump Box
- 110V Battery Charger
- PPG DTM 2 Part Epoxy Paint

### Specifications

<b>Axle:</b>	(2) 12,000 lb Lippert Torsion	<b>Floor &amp; Wall</b>	3/16" Floor / 12ga Wall
<b>Hoist:</b>	Champion CS620T 13 Ton	<b>Frame:</b>	Engineered Beam 90 KSI Steel
<b>Jack:</b>	(2) 14,000 lb Hydraulic Bolted	<b>Lights:</b>	LED
<b>Ramp:</b>	4,500 lb Mid Span	<b>Electric Plug:</b>	7 Wire RV
<b>Wheels:</b>	235/75R17.5 H Steel	<b>Safety Chains:</b>	26,400 lb
<b>Tailgate:</b>	Steel Two-Way Barn/Spreader	<b>Paint Specs</b>	PPG 2-Part Epoxy DTM
<b>Coupler:</b>	Gooseneck 2 5/16"		

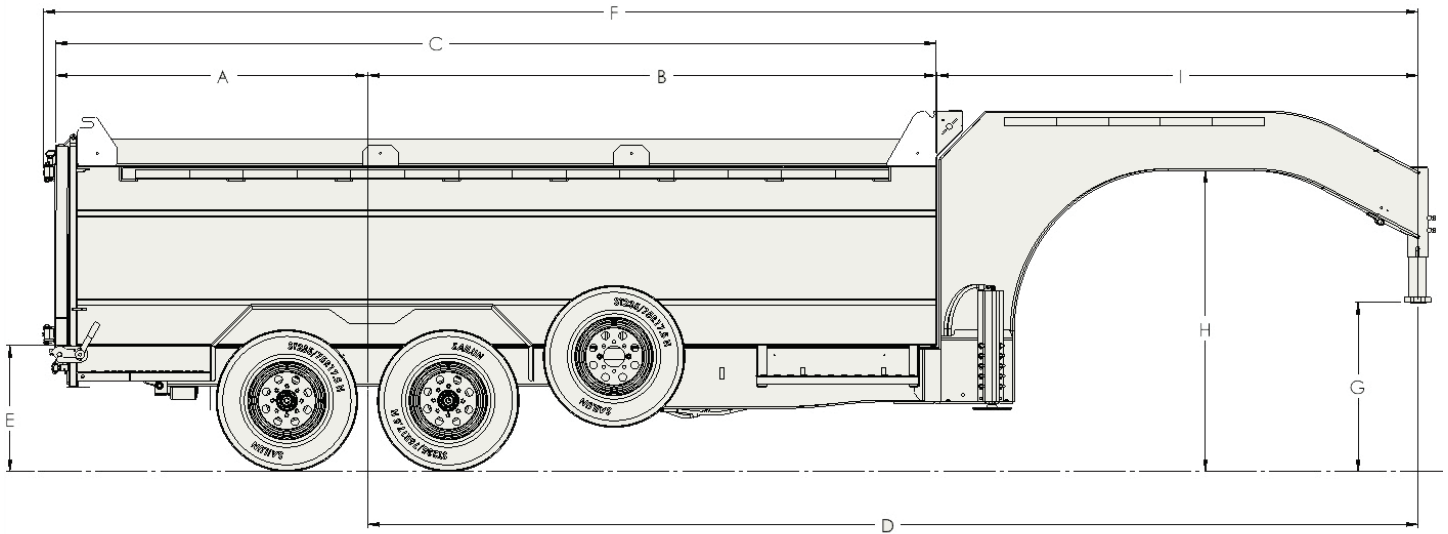

## Dimensions

Model	A	B	C	D	E	F	G	H	I
SL716G-24K	70"	127"	197"	234"	27 3/4"	307"	31 - 37"	67"	108"

Model	Description	Net Weight	GVWR	Payload Cap.
SL716G-24K	7' x 16' 24,000 lb. Tandem Axle Gooseneck	7,075 lb	27,600 lb	20,525 lb



Specs are subject to change without notice. Please contact Southland Trailer Corp Product Specialist for price confirmation on all Products. - Revised January 2024